

ROHS
Compatible

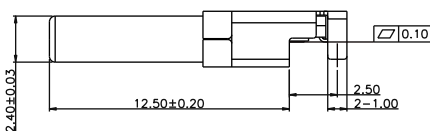
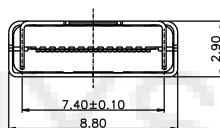
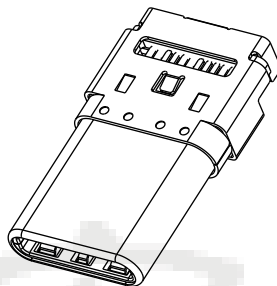
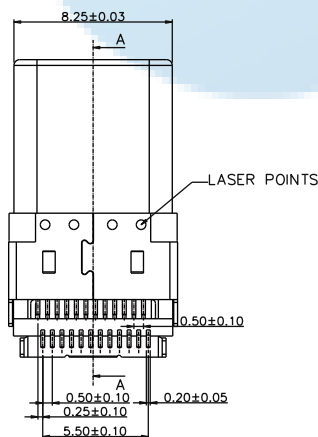
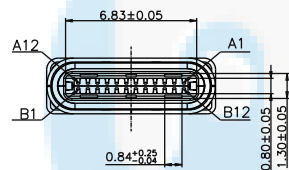
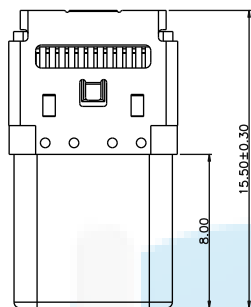

NOTE:

1.MATERIAL SPECIFICATION:

- 1-1.HOUSING: LCP,BLACK,UL94 V-0.
- 1-2.CONTACTS: C7025 T=0.15
- 1-3.LATCH: SUS301 T=0.40
- 1-4.BACK SHELL: SUS304 T=0.20;
- 1-4.FRONT SHELL: SUS316 T=0.15;
- 1-5.EMI: SUS301 T=0.10;
- 1-6.COVER: LCP,BLACK,UL94 V-0.

2.PLATING SPECIFICATION:

- 2-1.CONTACTS:
Ni 50u" MIN. UNDER PLATED OVER ALL.
Au3u" PLATED ON THE FUNCTIONAL AREA OF CONTACT.
80u" MIN. SN PLATED ON SOLDER AREA.
- 2-2.BACK SHELL&FRONT SHELL:
Ni 30u" MIN. UNDER PLATED OVER ALL.
- 2-3.EMI&LATCH:
CLEAN

3.MECHANICAL PERFORMANCE,

- 3-1.INSERTION FORCE: 5~20N.
- 3-2.REMOVAL FORCE: 6~20N.
- 3-3.DURABILITY: 10000 CYCLES.

4.ELECTRICAL PERFORMANCE,

- 4-1.CURRENT RATING: 5A For Pin(A4,A9,B4,B9)
1.25A For Others Pin
VOLTAGE RATING: 5.0V
- 4-2.INSULATION RESISTANCE: 100MΩ MIN.
- 4-3.DIELECTRIC WITHSTAND VOLTAGE,AC 100V FOR 1 MINUTE.
- 4-4.LOW CONTACT RESISTANCE: INITIAL 40mΩ AFTER 50mΩ

5. ENVIRONMENTAL PERFORMANCE:

OPERATING TEMPERATURE: -55°C~+85°C.

6.IR REFLOW:

THE PEAK TEMPERATURE ON THE BOARD SHALL BE MAINTAINED FOR 10 SECONDS AT 260°C.

7.Salt Spray :24H

U5 164- 24P x 1.3C 15.5L
↓ ↓ ↓ ↓ ↓
名称 流水号 PIN位 E;公头 C;沉板 L;长度

PIN ASSIGNMENT:

A1	GND	B12	GND
A2	SSTXP1	B11	SSRXP1
A3	SSTXN1	B10	SSRXN1
A4	VBUS	B9	VBUS
A5	CC1	B8	SBU2
A6	DP1	B7	DN2
A7	DN1	B6	DP2
A8	SBU1	B5	CC2
A9	VBUS	B4	VBUS
A10	SSRXN2	B3	SSTXN2
A11	SSRXP2	B2	SSTXP2
A12	GND	B1	GND
PIN	SIGNAL NAME	PIN	SIGNAL NAME

DESIGN	Li Jinwei	SCALL	
DRAWING	Wu Qifa	UNIT	mm
CHECK	Zheng Jinxian	SIZE	A4: 210 * 297
APPROVAL	Liu Xiaohong	DATE	2020-06-10

TOLERANCE	
X.X ±0.30	X.°±2°
.XX ±0.20	.X°±1°
.XXX ±0.10	.XX°±0.5°

DRAWG NO.	U5164-24PE1.3C15.5L
TITLE:	24P沉板1.3 两脚插板 SMT 15.50L

东莞市宏煜盛实业有限公司
 Dongguan hongyusheng Industry Co., Ltd
 TEL: 0769-81230179 <https://www.hystypec.com>

ROHS
Compatible

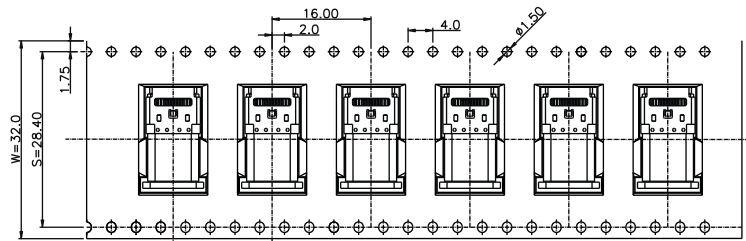

① 产品入载带示意图

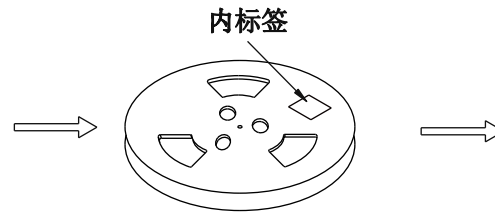

② 卷盘贴标签示意图

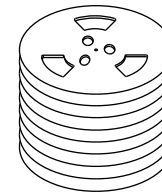

③ 产品叠层示意图

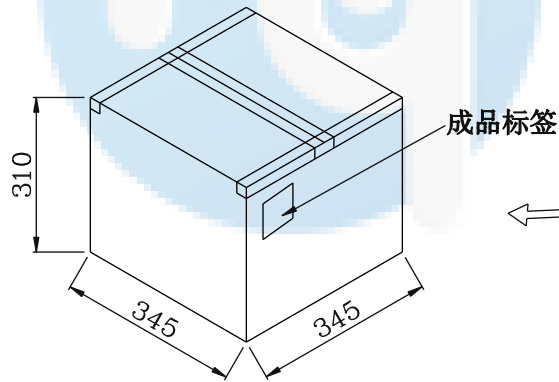

⑤ 外箱封箱示意图

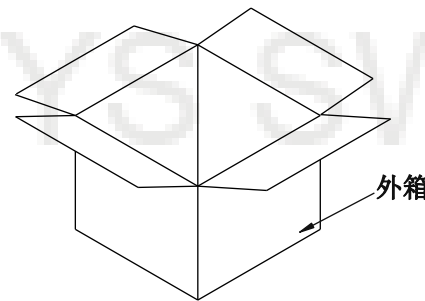

④ 产品入外箱示意图

包装说明:

1. 将检验好的成品;对插口朝前放入载带;每卷装1000PCS产品;具体如图一所示
2. 将包装好的产品;每盘必需贴上内标签;具体如图二所示
3. 将贴好内标签的产品每7盘叠;具体如图三所示
5. 装好后并封好纸箱及贴好相关标签;具体如图五所示;
(产品包装的标签,如客户有要求,请按客户要求包装出货)
6. 载带前面留22PCS空格,后面留22PCS空格

	REEL	CARTON
CONNECTOR (PCS)	1000	8000

DESIGN	Li Jinwei	SCALL		 TOLERANCE X.X ± 0.30 X. $^{\circ} \pm 2^{\circ}$.XX ± 0.20 .X. $^{\circ} \pm 1^{\circ}$.XXX ± 0.10 .XX. $^{\circ} \pm 0.5^{\circ}$
DRAWING	Wu Qifa	UNIT	mm	
CHECK	Zheng Jinxian	SIZE	A4: 210 * 297	
APPROVAL	Liu Xiaohong	DATE	2020-06-10	

DRAWG NO.	U5164-24PE1.3C15.5L
TITLE:	24P沉板1.3 两脚插板 SMT 15.50L



东莞市宏煜盛实业有限公司
Dongguan hongyusheng Industry Co., Ltd
TEL: 0769-81230179 <https://www.hystypec.com>