

ROHS
Compatible

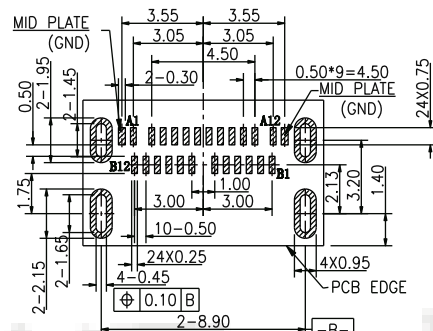

RECOMMENDED PCB LAYOUT
(TOLERANCE: ±0.05)

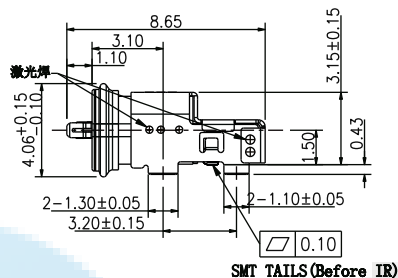
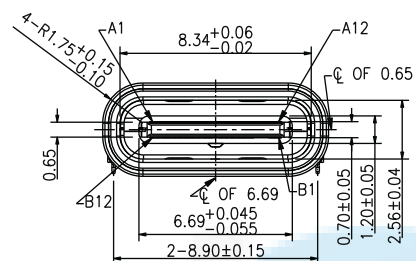
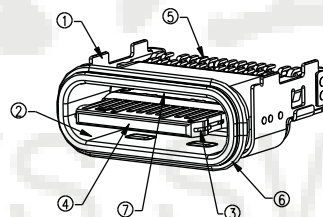
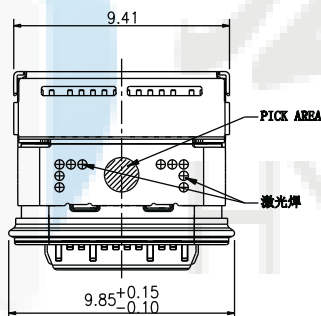
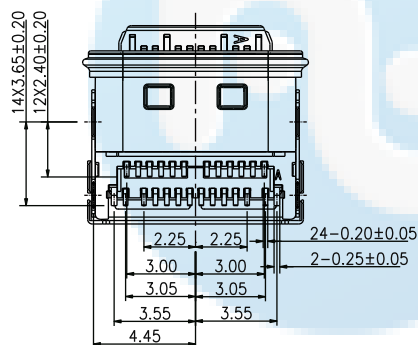

- NOTES:
- ELECTRICAL CHARACTERISTICS:
 - CONTACT CURRENT RATING: 5.0A FOR VBUS PIN AND ITS CORRESPONDING GND PIN.
 - CONTACT RESISTANCE: 30 MILLIOHMS MAX FOR VBUS AND GND CONTACTS. 40 MILLIOHMS MAX FOR ALL OTHER CONTACTS.
 - DIELECTRIC WITHSTANDING VOLTAGE: 100 VRMS AC MIN.
 - INSULATION RESISTANCE: 100 MEGOHMS MIN.
 - MECHANICAL CHARACTERISTICS:
 - CONNECTOR INSERTION FORCE: 5~20N. AT A MAXIMUM RATE OF 12.5MM PER MINUTE.
 - CONNECTOR EXTRACTION FORCE: 8~20N AT A MAXIMUM RATE OF 12.5MM PER MINUTE. 6~20N AFTER DURABILITY TEST.
 - DURABILITY: 10000 CYCLES.
 - OPERATING TEMPERATURE: -55°C TO +85°C
 - SALT SPRAY: 48HOURS.
 - DIMENSIONS ARE IN MILLIMETERS, BRACKETED DIMENSIONS ARE INCHES EQUIVALENTS.
 - RECOMMENDED PROCESS: IR REFLOW 260°C, 3~5SECONDS.
 - THE CONNECTOR IS ROHS COMPLIANT AND HALOGEN FREE COMPLIANT.
- U5 033- 24P x x 8.65L x
↓ ↓ ↓ ↓ ↓ ↓ ↓ ↓ ↓ ↓ ↓ ↓
名称 流水号 PIN位 N;母座 W;舌头外露 L;长度 F;防水

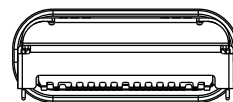
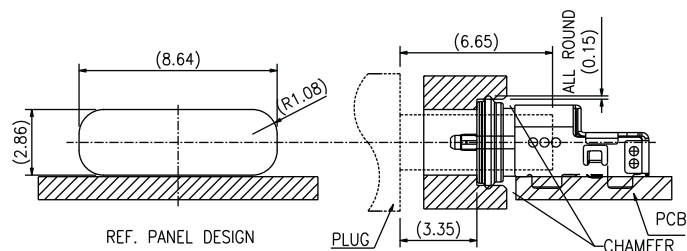

Pin	Signal Name	Pin	Signal Name	ITEM	PART NAME	Q'TY	Material&Plating
A1	GND	B12	GND	1	SUB-SHELL	1	SUS304 t=0.15, Ni PLATED 30u"
A2	SSTp1	B11	SSTp1	2	MAIN-SHELL	1	SUS316L t=0.20 CLEANING
A3	SSTn1	B10	SSTn1	3	LATCH	1	SUS301 t=0.15, Ni PLATED 30u"
A4	Yes	B9	Yes	4	HOUSING	1	PA9T+30%GF, HF BLACK
A5	CC1	B8	SMB2	5	CONTACT	24	C7025 t=0.12, Ni 50-150u" UNDER PLATED OVER. 30u" Au PLATED ON THE CONTACT AREA, 3-8u" Au PLATED ON
A6	Dp1	B7	Inc2	6	LIM	1	CHIN-SUMIBERO4ABS Pull force 300g
A7	Dn1	B6	Dp2	7	EMC	2	SUS304 t=0.10, CLEANING
A8	SMB1	B5	CC2				
A9	Yes	B4	Yes				
A10	SSTn2	B3	SSTn2				
A11	SSTp2	B2	SSTp2				
A12	GND	B1	GND				

DESIGN	Li Jinwei	SCALL		
DRAWING	Wu Qifa	UNIT	mm	
CHECK	Zheng Jinxian	SIZE	A4: 210 * 297	
APPROVAL	Liu Xiaohong	DATE	2020-06-10	

DRAWG NO. U5033-24PNW8.65LF
TITLE: 防水24P 板上四脚插板SMT 舌头外露 8.65L IPX8

东莞市宏煜盛实业有限公司
Dongguan hongyusheng Industry Co., Ltd
TEL: 0769-81230179 <https://www.hystypec.com>

ROHS
Compatible

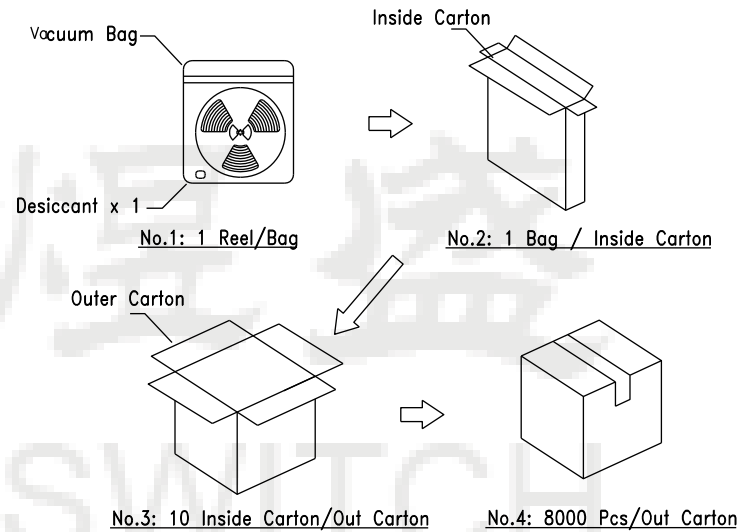
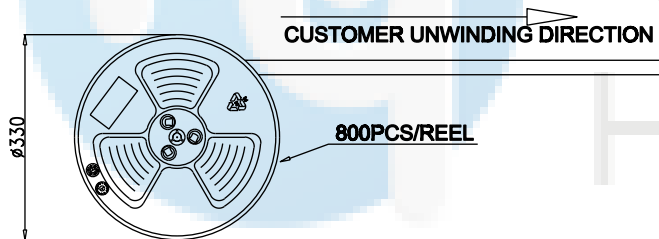
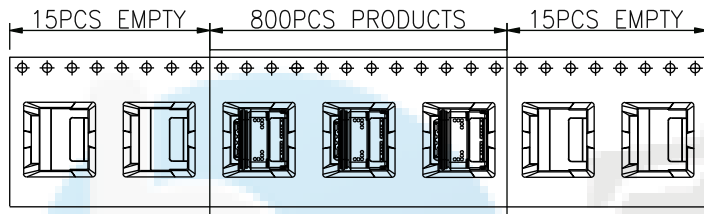

包装说明:

1. 将产品放入REEL卷中，然后贴上透明PE上带800PCS/卷；
2. 然后尾部用胶纸粘贴，在REEL卷盘上贴上数量标签；
3. 将包装好的产品放入指定的外箱中，一箱装10盘，8000 PCS/箱；
4. 出货标签要严格按照要求进行填写；
5. 纸箱封盖后以封箱胶封箱，贴上出货标签；
6. 外箱若客户另有贴标签要求，则按其订单注明之要求贴；
7. 纸箱尺寸及印刷见包材图面；
8. 未满足之零数箱需以缓冲材料填满，并贴上零数标签，写明具体数量；
9. 本包装适装产品：USB TYPE C母座24P 双排SMT 防水型；
10. ROHS+HF.

DESIGN	Li Jinwei	SCALL			DRAWG NO.	U5033-24PNW8.65LF
DRAWING	Wu Qifa	UNIT	mm		TOLERANCE	
CHECK	Zheng Jinxian	SIZE	A4: 210 * 297		TITLE:	防水24P 板上四脚插板SMT 舌头外露 8.65L IPX8
APPROVAL	Liu Xiaohong	DATE	2020-06-10			