

ROHS
Compatible

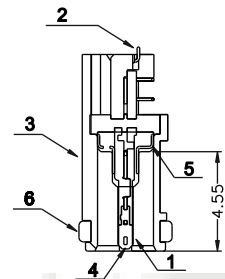

SPECIFICATION:

- 1.ELECTRICAL:
 1-1:CURRENT RATING:
 VBUS AND GND CONTACTS RATED AT 1.25A
 PARALLELED FOR A TOTAL OF 5A;
 1-2:INITIAL CONTACT RESISTANCE :40 MEGOHMS
 1-3:DIELECTRIC WITHSTANDING VOLTAGE:
 100V AC MIN;
 2:MECHANICAL CHARACTERISTICS:
 2-1:MATING FORCE:5~20N
 2-2:UNMATING FORCE:8~20N(INITIAL),
 6~20N(AFTER 10000 CYCLES)
 2-3:FREQUENCY: 200±50 CYCLES /HOUR,10000
 CYCLES
 2-4:OPERATING TEMPERATURE ;-40°~80°.
 3: WATERPROOF: IP-X7.
 U5 180- 24P x 0.93C 9.0L x
 ↓ ↓ ↓ ↓ ↓ ↓
 名称 流水号 PIN位 N:母座 C:沉板 L:长度 F:防水

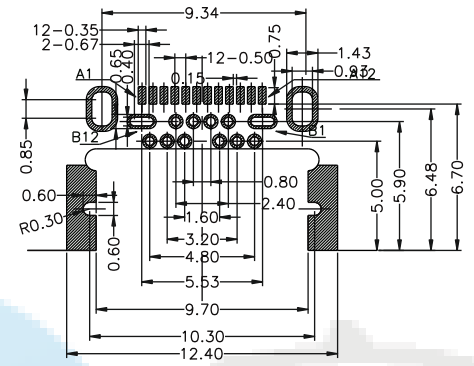
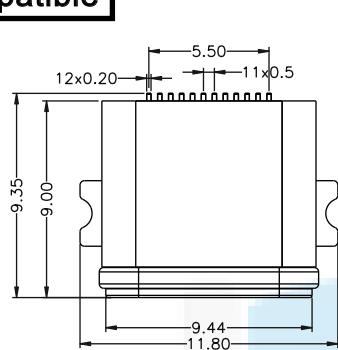
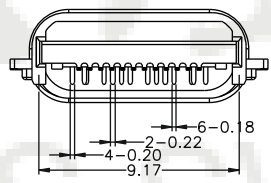
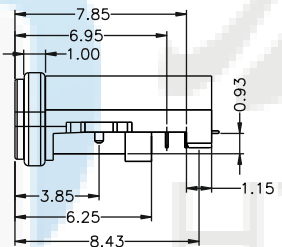
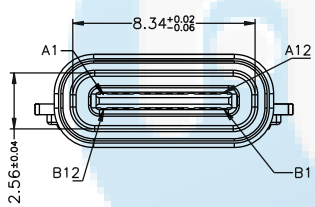
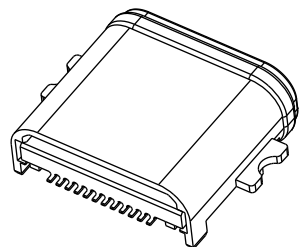
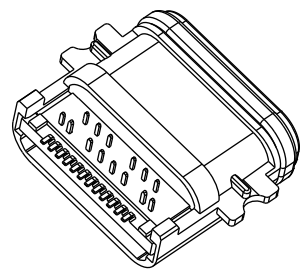
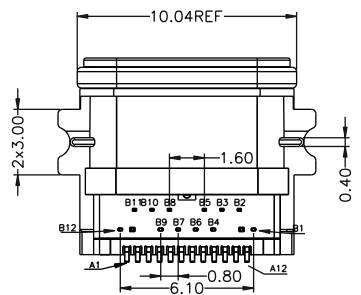

TABLE B

A1	GND	B12	GND
A2	SSTXP1	B11	SSRXP1
A3	SSTXN1	B10	SSRXN1
A4	VBUS	B9	VBUS
A5	CC1	B8	SBU2
A6	DP1	B7	DN2
A7	DN1	B6	DP2
A8	SBU1	B5	CC2
A9	VBUS	B4	VBUS
A10	SSRXN2	B3	SSTXN2
A11	SSRXP2	B2	SSTXP2
A12	GND	B1	GND

TABLE A

NO.	DESCRIPTION	MATERIAL	FINISH PLANTED	QTY	REMARKS
6	RING	SILICON	---	1PCS	
5	MID-PLANT	STAINLESS STEEL	---	1PCS	
4	GND-PLANT	STAINLESS STEEL	NI/SN Plated	1PCS	
3	SHELL	ZN-ALLOY	---	1PCS	
2	CONTACT	COPPER ALLOY	Au/Ni Plated	2SET	
1	HOUSING	HIGH TEMPERATURE PLASTIC	BLACK	1PCS	



DESIGN	Li Jinwei	SCALL	
DRAWING	Wu Qifa	UNIT	mm
CHECK	Zheng Jinxian	SIZE	A4: 210 * 297
APPROVAL	Liu Xiaohong	DATE	2020-06-10

⊕	
TOLERANCE	
X.X ±0.30	X.°±2°
.XX ±0.20	.X°±1°
.XXX ±0.10	.XX°±0.5°

DRAWG NO. U5180-24PN0.93C9.0LF
 TITLE: 防水24P 前贴后插DIP + SMT 沉板0.93mm 9.0L IPX7



东莞市宏煜盛实业有限公司
 Dongguan hongyusheng Industry Co., Ltd
 TEL: 0769-81230179 <https://www.hystypec.com>