

ROHS
Compatible

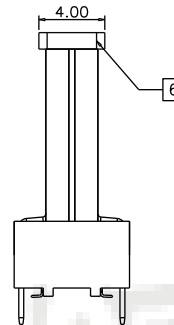

NOTE:
 1.Contact Resistance:40mOHM Max.;
 2.Dielectric Withstanding Voltage:100V AC For 1 Minute;
 3.Insulation Resistance:100M OHM Min.;
 4.Mating And Unmating Force:
 Mating Force: 5~20N
 Unmating Force: 8~20N;
 6~20N AFTER TEST;
 5.Durability:10000 Cycles;
 6. PART NUMBER CODE:
 U5 157- 24P x 15.0L
 ↓ ↓ ↓ ↓ ↓
 名称 流水号 PIN位 N;母座 L;长度

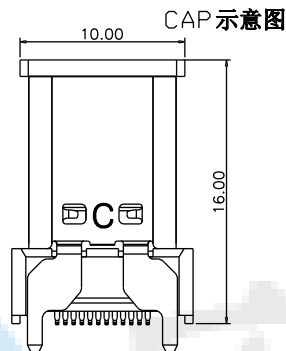
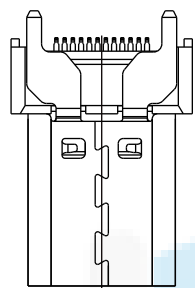
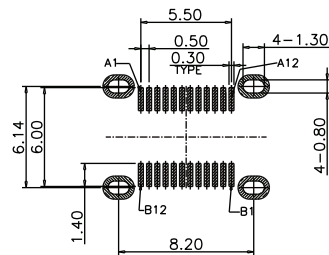
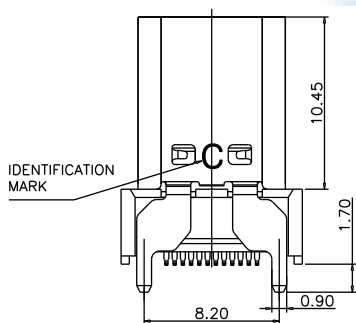
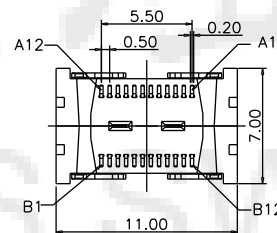
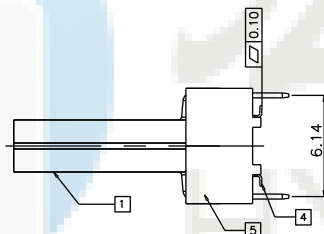
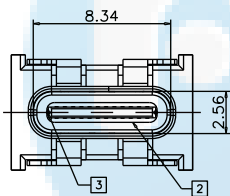

RECOMMEND P.C.B LAYOUT(COMPONENT SIDE)
 TOLERANCE FOR PCB LAYOUT IS ± 0.05
 KEEP OUT AREA

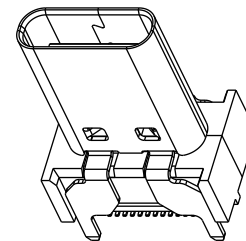

USB TYPE-C PIN ASSIGNMENTS

PIN NUMBER	SIGNAL NAME	PIN NUMBER	SIGNAL NAME
A1	GND	B12	GND
A2	SSTxp1	B11	SSRXp1
A3	SSTxn1	B10	SSRXn1
A4	Vbus	B9	Vbus
A5	CC1	B8	SBU2
A6	Dp1	B7	Dn2
A7	Dn1	B6	Dp2
A8	SBU1	B5	CC2
A9	Vbus	B4	Vbus
A10	SSRXn2	B3	SSTxn2
A11	SSRXp2	B2	SSTxp2
A12	GND	B1	GND

Item	Title	Material	Dispose	Q'TY
1	Shell	SUS304	Ni:30u" Min.	1PCS
2	GND Plate	SUS301		2PCS
3	Mid Plate	SUS301		1PCS
4	Contact	C7025	Mating Area: See P/N Solder Tails: Matt Tin	2PCS
5	InsertMolding	LCP E6808	UL 94V-0 Block	1PCS
6	COVER	LCP E6808	UL 94V-0 Block	1PCS

DESIGN	Li Jinwei	SCALL	
DRAWING	Wu Qifa	UNIT	mm
CHECK	Zheng Jinxian	SIZE	A4: 210 * 297
APPROVAL	Liu Xiaohong	DATE	2020-06-10

⌀	
TOLERANCE	
X.X ±0.30	X.°±2°
.XX ±0.20	.X°±1°
.XXX ±0.10	.XX°±0.5°

DRAWG NO.	U5157-24PN15.0L
TITLE:	24P立式四脚插板SMT 15.0L

东莞市宏煜盛实业有限公司
 Dongguan hongyusheng Industry Co., Ltd
 TEL: 0769-81230179 <https://www.hystypec.com>

ROHS
Compatible

AROUND THE OUTER PERIPHERY IN A TURE,
WEEDING THE COVER TAPE.

PELLING ANGLE: 165°X~180°X

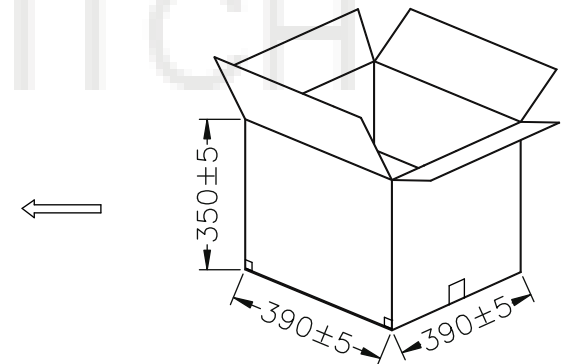
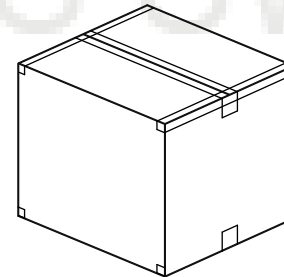
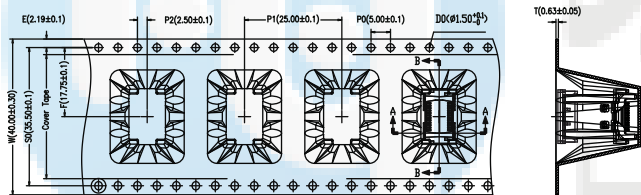
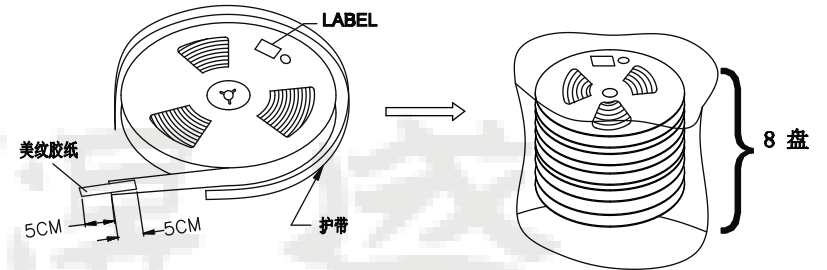
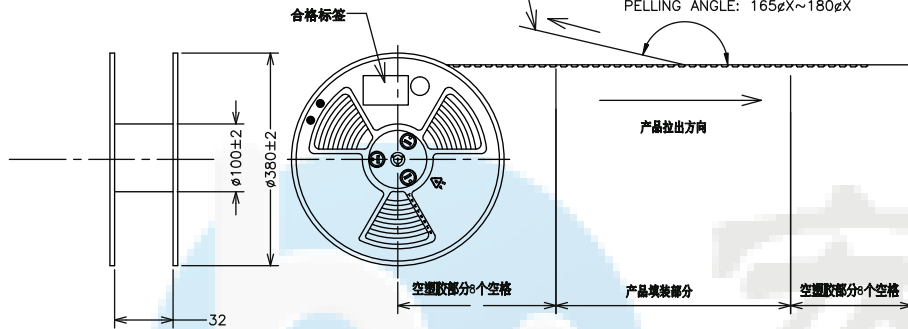

说明:

- 1, 将检查合格的产品, 放入承载带中, 一盘包装200PCS;
- 2, 将8盘承载带放入纸箱中;
- 3, 将纸箱封装好, 贴上标签.

每箱数量	净重 (Kg)	毛重 (Kg)
1600PCS	XXX	XXX

DESIGN	Li Jinwei	SCALL	
DRAWING	Wu Qifa	UNIT	mm
CHECK	Zheng Jinxian	SIZE	A4: 210 * 297
APPROVAL	Liu Xiaohong	DATE	2020-06-10

DRAWG NO.	U5157-24PN15.0L
TITLE:	24P立式四脚插板SMT 15.0L



东莞市宏煜盛实业有限公司
Dongguan hongyusheng Industry Co., Ltd
TEL: 0769-81230179 <https://www.hystypec.com>