

ROHS
Compatible

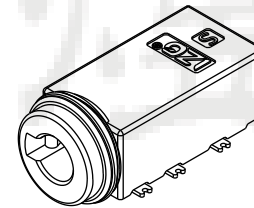

- NOTES
- CURRENT RATING: 1A.
 - CONTACT RESISTANCE: 100mΩ MAX.
 - INSULATION RESISTANCE: 100MΩ MIN.
 - DIELECTRIC WITHSTANDING: 500V AC MIN.
 - DURABILITY: 5000 CYCLES MIN.
 - CONNECTOR MATING FORCES: 3~30N.
 - CONNECTOR UNMATING FORCES: 3~30N.
 - OPERATING TEMPERATURE: -25°C TO +85°C.
 - WATERPROOF LEVEL: IP67

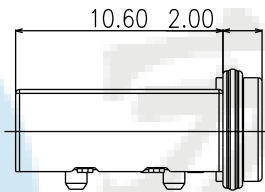
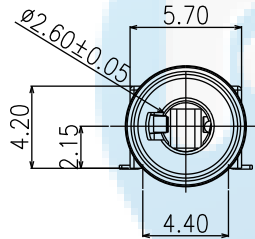
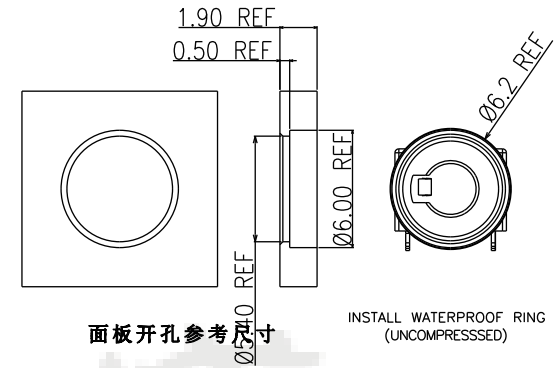
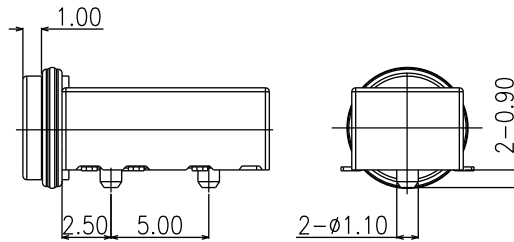
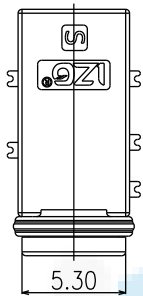
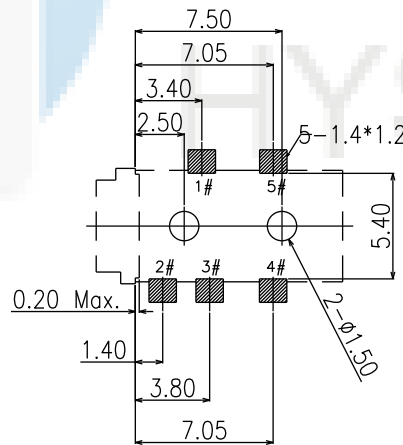

RECOMMEND PCB LAYOUT
TOLERANCE: ±0.05

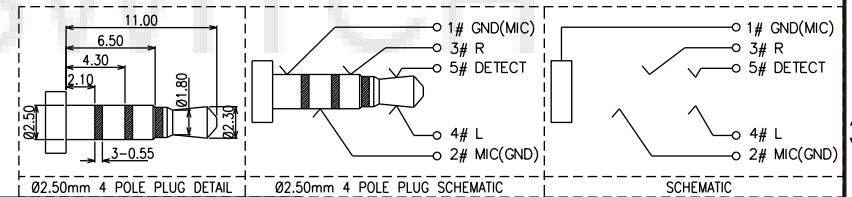

9		1	EPOXY; BLACK
8		1	SILICONE; BLACK
7		1	HIGH TEMPERATURE; BLACK
6		1	HIGH TEMPERATURE; BLACK
5	TERMINAL 5#	1	STAINLESS STEEL; NICKEL UNDERPLATING OVERALL, GOLD FLASH PLATING ON THE SOLDER & CONTACT AREA
4	TERMINAL 4#	1	STAINLESS STEEL; NICKEL UNDERPLATING OVERALL, GOLD FLASH PLATING ON THE SOLDER & CONTACT AREA
3	TERMINAL 3#	1	PHOSPHOR BRONZE; NICKEL UNDERPLATING OVERALL, GOLD FLASH PLATING ON THE SOLDER & CONTACT AREA
2	TERMINAL 2#	1	PHOSPHOR BRONZE; NICKEL UNDERPLATING OVERALL, GOLD FLASH PLATING ON THE SOLDER & CONTACT AREA
1	TERMINAL 1#	1	STAINLESS STEEL; NICKEL UNDERPLATING OVERALL, GOLD FLASH PLATING ON THE SOLDER & CONTACT AREA
ITEM	NAME	QTY	DESCRIPTION

Not to install the waterproof ring shipment

DESIGN	Li Jinwei	SCALL	
DRAWING	Wu Qifa	UNIT	mm
CHECK	Zheng Jinxian	SIZE	A4: 210 * 297
APPROVAL	Liu Xiaohong	DATE	2020-06-10

TOLERANCE	
X.X ±0.30	X.°±2°
.XX ±0.20	.X°±1°
.XXX ±0.10	.XX°±0.5°

DRAWG NO.	PJ-551F
TITLE:	防水Φ2.5mm耳机插座

 **东莞市宏煜盛实业有限公司**
Dongguan hongyusheng Industry Co., Ltd
TEL: 0769-81230179 <https://www.hystypec.com>