

ROHS
Compatible

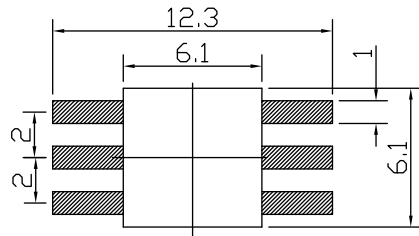

P. C. B LAYOUT

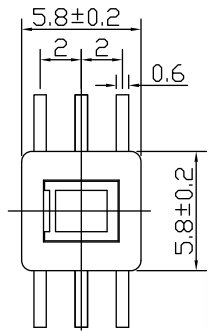
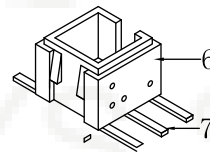
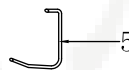
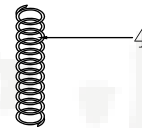
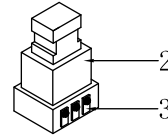
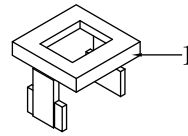
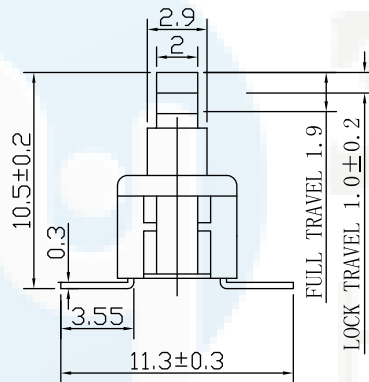
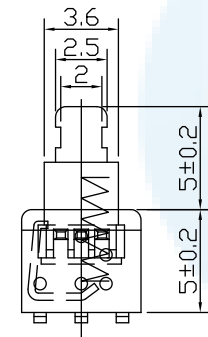

ELECTRICAL CHARACTERISTICS

1. RATING: DC 30V 0.1A
2. CONTACT RESISTANCE: 100mΩ MAX
3. INSULATION RESISTANCE: 100MΩ MIN
4. DIELECTRIC STRENGTH: AC 250V (50~60Hz) /60S

MECHANICAL CHARACTERISTICS

1. PRACTICAL TEMPERATURE RANG: -40℃~+85℃
2. OPERATING FORCE: 250±50gf
3. MECHANICAL LIFE: 30,000 cycles

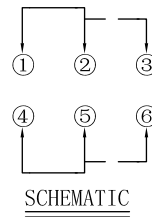
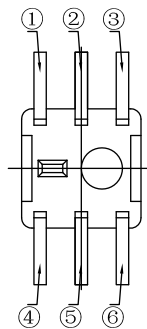

SCHMATIC

7	TERMINAL	BRASS STRIP	6	Ag PLATED
6	CASE	PPA	1	GRAY
5	LOCK PIN	SUS WIRE	1	NATURAL
4	SPRING	SUS WIRE	1	NATURAL
3	CONTACT	PBS	2	Ag PLATED
2	KNOB	PPA	1	WHITE
1	COVER	PPA	1	BLACK
NO.	PART NAME	MATERIAL	QTY.	FINISHING

DESIGN	Li Jinwei	SC ALL	
DRAWING	Wu Qifa	UNIT	mm
CHECK	Zheng Jinxian	SIZE	A4: 210 * 297
APPROVAL	Liu Xiaohong	DATE	2020-06-10

TOLERANCE	
X.X ±0.30	X.°±2°
.XX ±0.20	.X°±1°
.XXX ±0.10	.XX°±0.5°

DRAWG NO.	PS-5849SD-L1
TITLE:	按键开关



东莞市宏煜盛实业有限公司
Dongguan hongyusheng Industry Co., Ltd
TEL: 0769-81230179 <https://www.hystypec.com>