

ROHS
Compatible

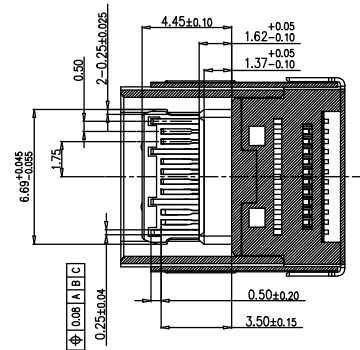

SECTION A-A

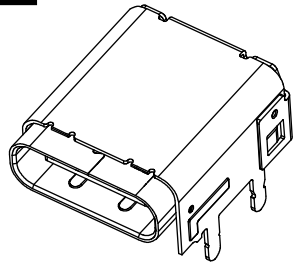
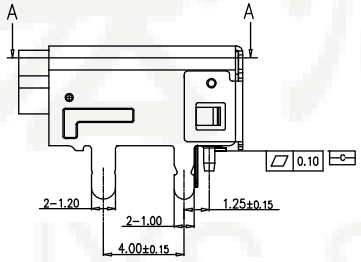
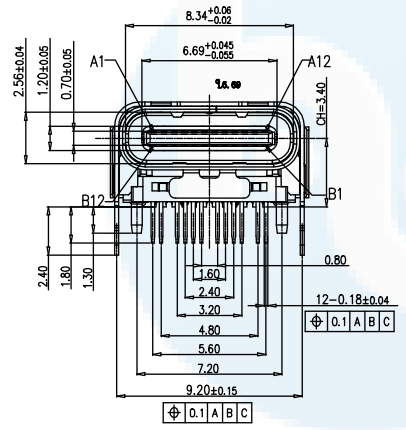
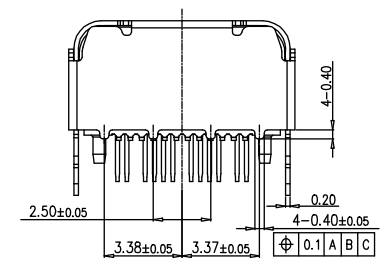

NOTES:

- 1.MATERIAL :SEE TABLE
- 2.COPLANARITY : 0.10 Max.
- 3.ELECTRICAL CHARACTERISTICS
 LOW LEVEL CONTACT RESISTANCE: 40mΩ Max
 INSULATION RESISTANCE: 100MΩ MIN
 DIELECTRIC WITHSTANDING VOLTAGE: 100 VAC:
 CONTACT CURRENT RATING: 5A Max
- 4.MECHANICAL CHARACTERISTICS
 INSERTION FORCE: 5~20N
 EXTRACTION FORCE: 8~20N
 AFTER DURABILITY EXTRACTION FORCE: 6~20N
- 5.DURABILITY: 10000 CYCLES
- 6.PACKAGING TYPE: CARRIER TAPE.
- 7.SALT SPRAY : 24 HOURS

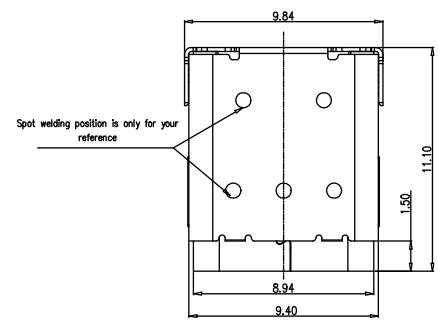
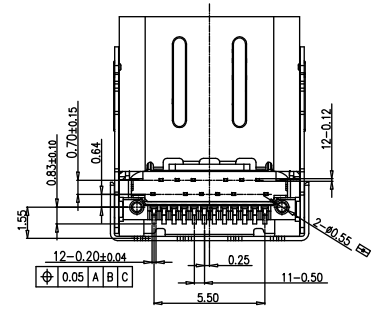

ITEM	DESCRIPTION	Q'TY	MATERIAL	FINISH
6	OUTER-SHELL	1	STAINLESS STEEL	SOLDER NICKEL: 50U" MIN
5	INNER-SHELL	1	STAINLESS STEEL	SOLDER NICKEL: 50U" MIN
4	TOP TERMINAL	1	COPPER ALLOY	MATING AREA: AU 15u" SOLDER TAIL: MATTE TIN 50 MIN, 50u" NICKEL OVERALL.
3	BOTTOM TERMINAL	1	COPPER ALLOY	MATING AREA: AU 15u" SOLDER TAIL: MATTE TIN 50 MIN, 50u" NICKEL OVERALL.
2	MID PLATE	1	STAINLESS STEEL	SOLDER NICKEL: 50U" MIN
1	MAIN HOUSING	1	HIGH TEMPERATURE BLACK	

BILL OF MATERIAL

DESIGN	Li Jinwei	SCALL	
DRAWING	Wu Qifa	UNIT	mm
CHECK	Zheng Jinxian	SIZE	A4: 210 * 297
APPROVAL	Liu Xiaohong	DATE	2020-06-10

TOLERANCE	
.XX ±0.30	.X.°±2°
.XX ±0.20	.X° ±1°
.XXX ±0.10	.XX°±0.5°

DRAWG NO. TYPE-C-DSJG24PZ111
 TITLE: 24P垫高3.4四脚插板DIP+SMT 11.1L

东莞市宏煜盛实业有限公司
 Dongguan hongyusheng Industry Co., Ltd
 TEL: 0769-81230179 <https://www.hystypec.com>

ROHS
Compatible

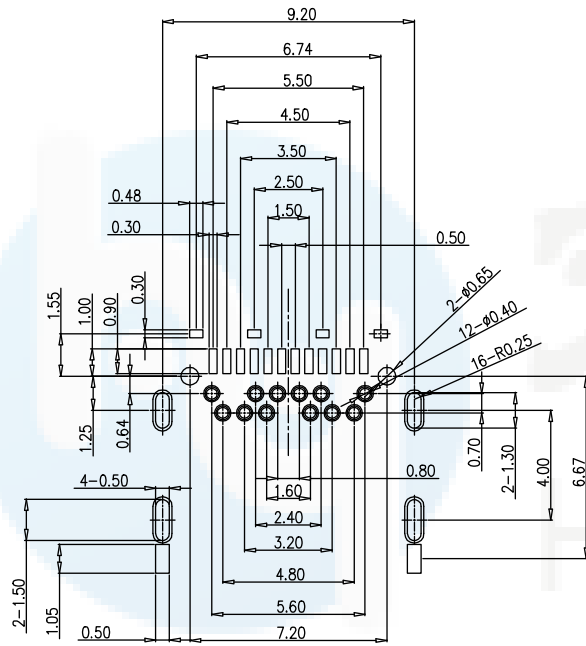

RECOMMENDED P. C. B LAYOUT (COMPONENT SIDE)

PCB THICKNESS: 2.0 ± 0.05mm

Pin No	Signal Name	Mating Sequence	Pin No	Signal Name	Mating Sequence
A1	GND	First	B12	GND	First
A2	TX1+	Second	B11	RX1+	Second
A3	TX1-	Second	B10	RX1-	Second
A4	Vbus	First	B9	Vbus	First
A5	CC1	Second	B8	SBU2	Second
A6	D+	Second	B7	D-	Second
A7	D-	Second	B6	D+	Second
A8	SBU1	Second	B5	CC2	Second
A9	Vbus	First	B4	Vbus	First
A10	RX2-	Second	B3	TX2-	Second
A11	RX2+	Second	B2	TX2+	Second
A12	GND	First	B1	GND	First
SHELL		GND	SHELL		GND

DESIGN	Li Jinwei	SCALL	
DRAWING	Wu Qifa	UNIT	mm
CHECK	Zheng Jinxian	SIZE	A4: 210 * 297
APPROVAL	Liu Xiaohong	DATE	2020-06-10

TOLERANCE	
X.X ±0.30	X.° ±2°
.XX ±0.20	.X° ±1°
.XXX ±0.10	.XX° ±0.5°

DRAWG NO.	TYPE-C-DSJG24PZ111
TITLE:	24P垫高3.4四脚插板DIP+SMT 11.1L

东莞市宏煜盛实业有限公司
 Dongguan hongyusheng Industry Co., Ltd
 TEL: 0769-81230179 <https://www.hystypec.com>