

SECTION:A-A

USB TYPE-C PIN ASSIGNMENTS

PIN NUMBER	SIGNAL NAME	PIN NUMBER	SIGNAL NAME
A1	GND	B12	GND
A4	VBus	B9	VBus
A5	CC1	B8	SBU2
A6	Dp1	B7	Dn2
A7	Dn1	B6	Dp2
A8	SBU1	B5	CC2
A9	VBus	B4	VBUS
A12	GND	B1	GND

DESIGN	Li Jinwei	SCALL	
DRAWING	Hu Lilin	UNIT	mm
CHECK	Ke Tao	SIZE	A4:210*297
APPROVAL	Zhang Hui	DATE	2020-03-25

TOLERANCE	
X.X ±0.30	X.*±2*
.X ±0.20	.X*±1*
.XXX ±0.10	.XXX*±0.5*

DRAWG NO: TYPE-C-DJT16P  
 TITLE: 双排16P 全DIP型插板

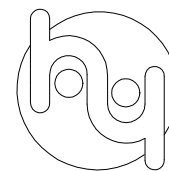

**东莞市宏煜盛实业有限公司**  
 Dongguan hongyusheng Industrial Co., Ltd  
 TEL:0769-81230179 <https://www.hystypec.com>

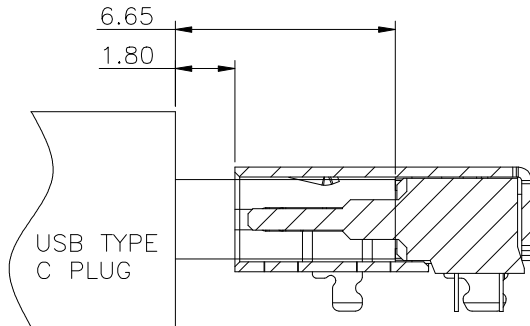

- NOTE:
- MATERIAL SPECIFICATION:
    - HOUSING: LCP, UL94 V-0.
    - CONTACTS: COPPER ALLOY (C1814)
    - MID PLATE: STAINLESS STEEL (SUS301)
    - FRONT SHELL: STAINLESS STEEL (SUS304)
  - PLATING SPECIFICATION:
    - TERMINAL:
      - Ni 50u" MIN. UNDER PLATED OVER ALL.
      - Au PLATED ON THE FUNCTIONAL AREA OF CONTACT. (GOLD PLATING THICKNESS FOLLOW THE P/N)
      - PLATING SPECIFICATIONS OF THE SOLDER AREA FOLLOW THE P/N
    - FRONT SHELL:
      - PLATING SPECIFICATIONS FOLLOW THE P/N
    - MID PLATE &:
      - CLEAR ONLY
  - MECHANICAL PERFORMANCE,
    - INSERTION FORCE: 0.5~2.0kgf.
    - REMOVAL FORCE: 0.8kgf~2.0kgf.
    - DURABILITY: 10000 CYCLES.
  - ELECTRICAL PERFORMANCE,
    - CURRENT RATING: 5.0A  
VOLTAGE RATING: 5.0V
    - LLCR:
      - VBUS & GND PINS AND OTHER PINS: 40mΩ/PIN MAX.
      - SHIELD: 50mΩ/MAX.
      - LLCR MAX. CHANGE OF ALL PINS: 10mΩ.
    - INSULATION RESISTANCE: 100MΩ MIN
    - DIELECTRIC WITHSTAND VOLTAGE, AC 100V FOR 1 MINUTE.
  - ENVIRONMENTAL PERFORMANCE:
    - OPERATING TEMPERATURE: -25°C~+85°C.
  - IR REFLOW:
    - THE PEAK TEMPERATURE ON THE BOARD SHALL BE MAINTAINED FOR 10 SECONDS AT 260°C.

AFTER MATING

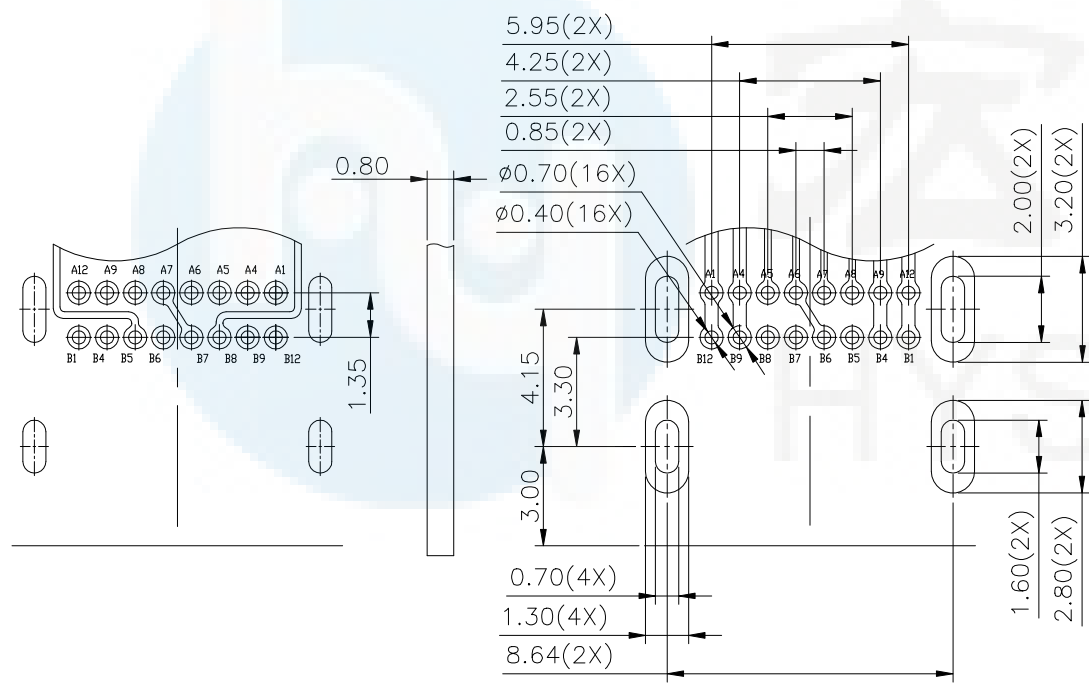

PCB BOTTOM SURFACE

RECOMMENDED PCB LAYOUT (TOP VIEW)

DEFAULT TOLERANCE: ±0.05

DESIGN	Li Jinwei	SCALL		 TOLERANCE X.X ±0.30 X.*±2° .X ±0.20 .X*±1° .XXX ±0.10 .XXX*±0.5°
DRAWING	Hu Lilin	UNIT	mm	
CHECK	Ke Tao	SIZE	A4:210*297	
APPROVAL	Zhang Hui	DATE	2020-03-25	

DRAWG NO:	TYPE-C-DJT16P
TITLE:	双排16P 全DIP型插板

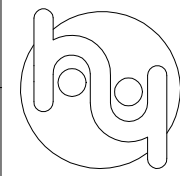

**东莞市宏煜盛实业有限公司**  
 Dongguan hongyusheng Industrial Co., Ltd  
 TEL: 0769-81230179 <https://www.hystypec.com>

REEL OFF SECTION (22 POCKETS MIN)      1000PCS PRODUCTS      PULL OUT DIRECTION (22 POCKETS MIN)

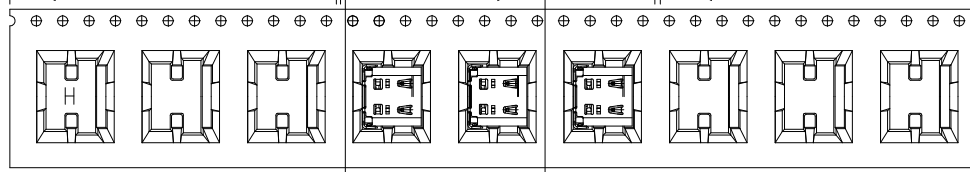

SEE DETAIL X

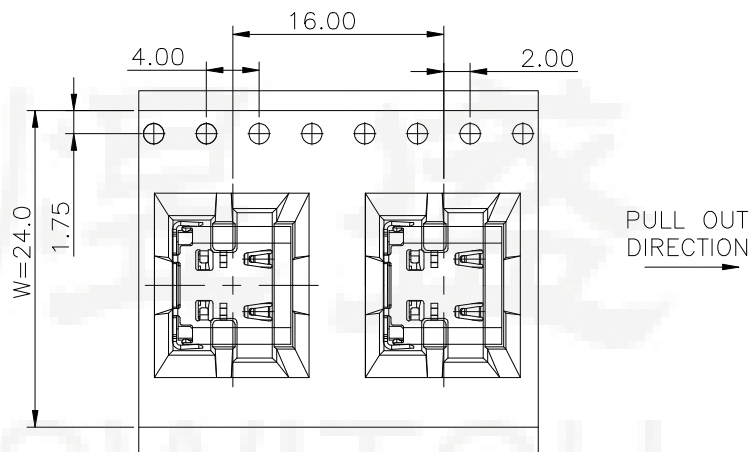
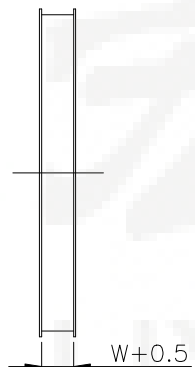
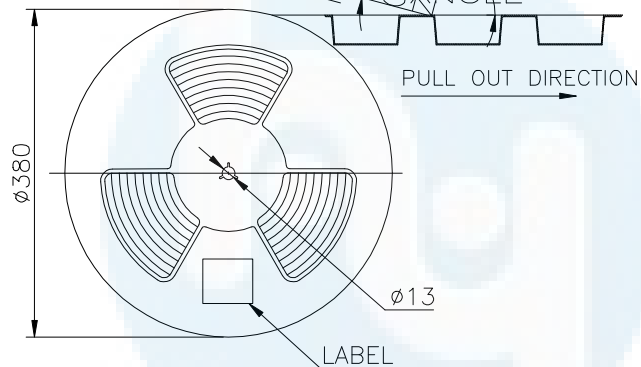

DETAIL X

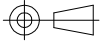
DESIGN	Li Jinwei	SCALL		 TOLERANCE X.X ±0.30    X.*±2* .X ±0.20    .X*±1* .XXX ±0.10    .XXX*±0.5*
DRAWING	Hu Lilin	UNIT	mm	
CHECK	Ke Tao	SIZE	A4:210*297	
APPROVAL	Zhang Hui	DATE	2020-03-25	

DRAWG NO:

TITLE:

双排16P 全DIP型插板

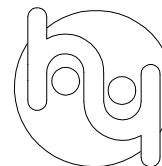

东莞市宏煜盛实业有限公司

Dongguan hongyusheng Industrial Co., Ltd

TEL:0769-81230179 <https://www.hystypec.com>