

ROHS
Compatible

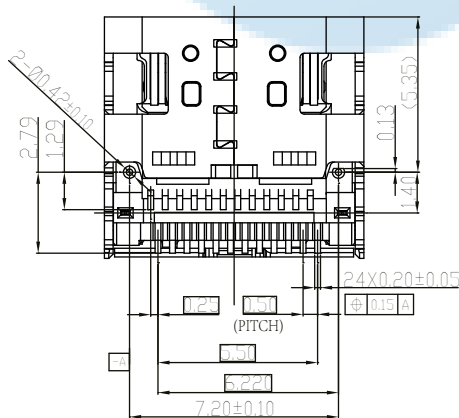
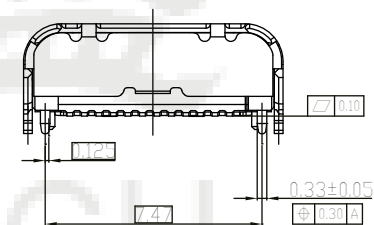
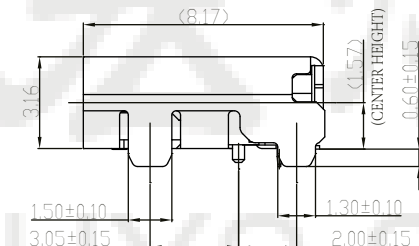
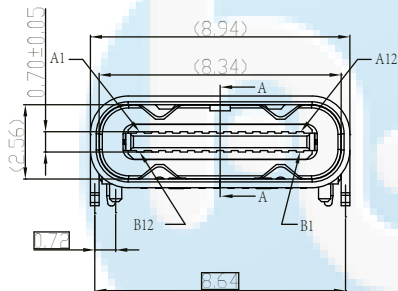
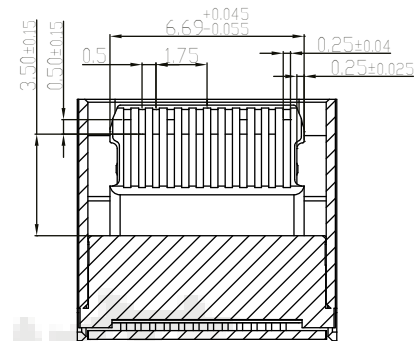
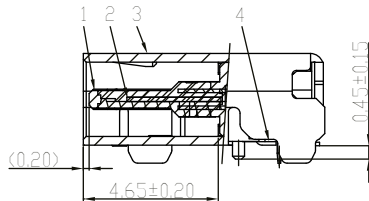
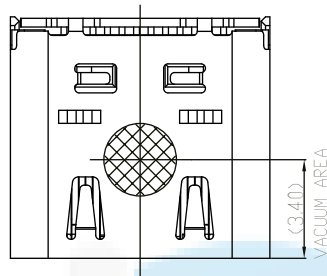

NOTE/注释:

1. SPECIFICATION/规格:

- 1.1 Rated current (额定电流): 1.5A/Pin MAX (A4, A9, B4, B9)
 - 1.25A/Pin MAX (A1, A12, B1, B12), 0.25A (OTHER PIN)
 - 1.2 Voltage rating (额定电压): 5V AC
 - 1.3 Contact Resistance (接触阻抗): 40 m Ω Max.
 - 1.4 Insulation Resistance (绝缘阻抗): 100MΩ Min.
 - 1.5 Withstanding voltage (耐电压): 100 VAC/minute
 - 1.6 Mating force (插入力): 5~20N.
 - 1.7 Unmating force (拔出力): 8~20N.
 - 1.8 Durability Cycle(寿命循环): 10,000 cycle
 - 1.9 Operating temperature (工作温度): -40° ~+85°
- 名称 流水号 PIN位 N;母座 T;带弹 L;长度

H=镀金1u"
J=镀金3u"
K=镀金5u"
M=镀金15u"
N=镀金30u"

PIN ASSIGNMENT:

A1	A2	A3	A4	A5	A6	A7	A8	A9	A10	A11	A12
GND	TX1+	TX1-	Vbus	CC1	D+	D-	SBU1	Vbus	RX2-	RX2+	GND
GND	RX1+	RX1-	Vbus	SBU2	D-	D+	CC2	Vbus	TX2-	TX2+	GND
B12	B11	B10	B9	B8	B7	B6	B5	B4	B3	B2	B1

DESIGN	Li Jinwei	SCALL	
DRAWING	Wu Qifa	UNIT	mm
CHECK	Zheng Jinxian	SIZE	A4: 210 * 297
APPROVAL	Liu Xiaohong	DATE	2020-06-10

TOLERANCE	
.XX ±0.30	.X° ±2°
.XX ±0.20	.X° ±1°
.XXX ±0.10	.XX° ±0.5°

DRAWG NO.	U5179-24PNT8.17L
TITLE:	24P 板上型四脚插板SMT有柱带弹 8.17L

 **东莞市宏煜盛实业有限公司**
Dongguan hongyusheng Industry Co., Ltd
TEL: 0769-81230179 <https://www.hystypec.com>

ROHS
Compatible

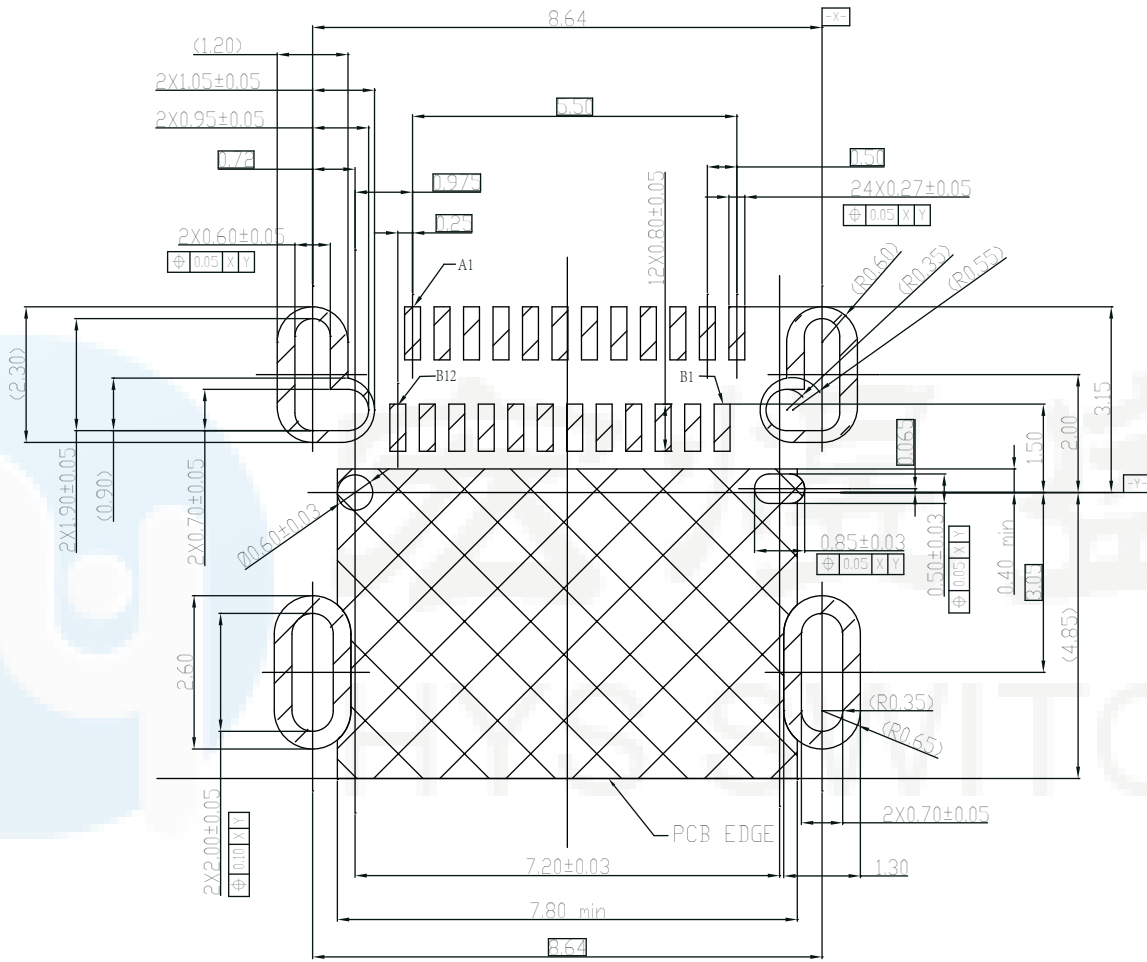

4	TERMINAL	24	C18140	MATING SIDE SEE PART NO; SOLDER TAIL: Gold FLASH, 50u" NICKEL OVERALL.	T=0.12
3	SHELL	1	SUS304	NICKEL PLATING	T=0.30
2	MID PLATE	1	SUS301	NICKEL PLATING	T=0.15
1	MAIN HOUSING	1	PA9T HF 30%玻纤, UL94 V-0, 黑色		BLACK UL94V-0
ITEM	DESCRIPTION	Q'TY	MATERIAL	FINISH	REMARK
BILL OF MATERIAL					

DESIGN	Li Jinwei	SC ALL	
DRAWING	Wu Qifa	UNIT	mm
CHECK	Zheng Jinxian	SIZE	A4: 210 * 297
APPROVAL	Liu Xiaohong	DATE	2020-06-10

TOLERANCE	
.XX	±0.30 X.°±2°
.XX	±0.20 .X.°±1°
.XXX	±0.10 .XX°±0.5°

DRAWG NO.	U5179-24PNT8.17L
TITLE:	24P 板上型四脚插板SMT有柱带弹 8.17L

东莞市宏煜盛实业有限公司
Dongguan hongyusheng Industry Co., Ltd
TEL: 0769-81230179 <https://www.hystypec.com>

ROHS
Compatible

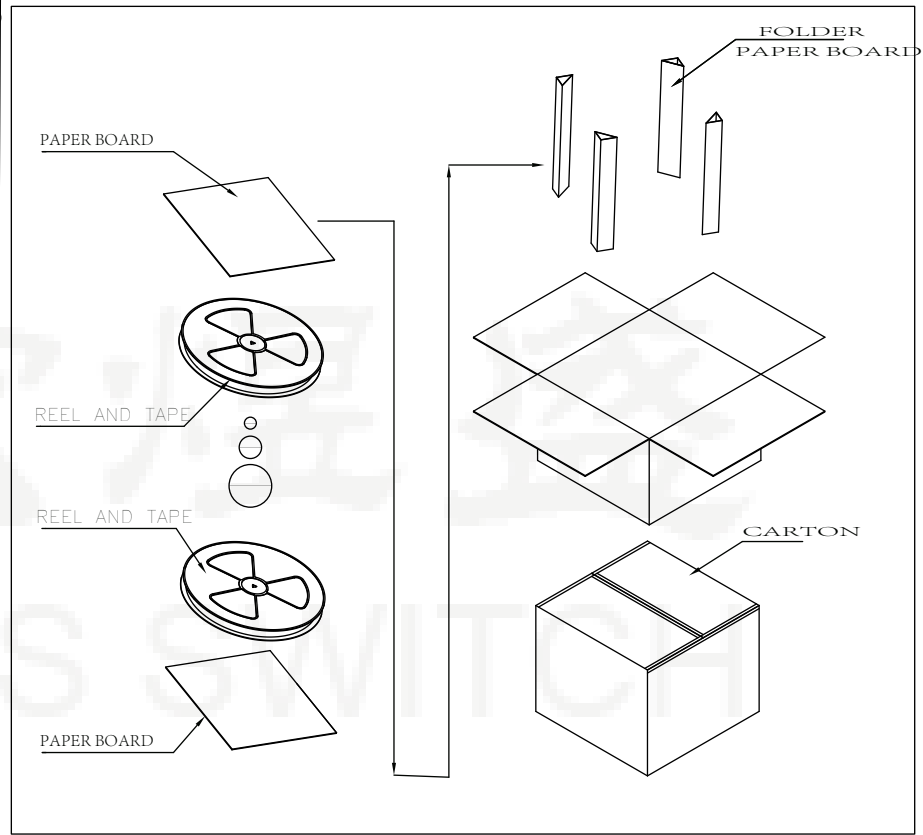
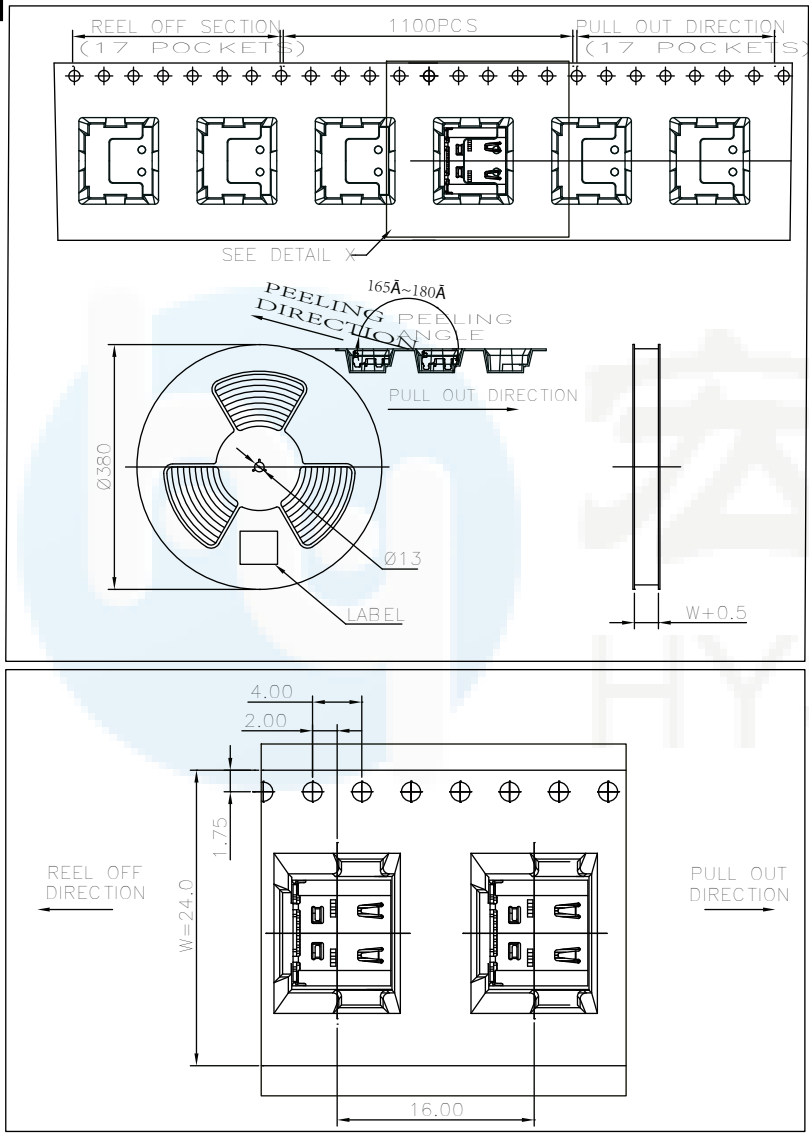

	REEL	CARTON
CONNECTOR (PCS)	1100	11000

DESIGN	Li Jinwei	SC ALL	
DRAWING	Wu Qifa	UNIT	mm
CHECK	Zheng Jinxian	SIZE	A4: 210 * 297
APPROVAL	Liu Xiaohong	DATE	2020-06-10

DRAWG NO.	U5179-24PNT8.17L
TOLERANCE	X.X ±0.30 X.°±2° .XX ±0.20 .X°±1° .XXX ±0.10 .XX°±0.5°
TITLE:	24P 板上型四脚插板SMT有柱带弹 8.17L

东莞市宏煜盛实业有限公司
Dongguan hongyusheng Industry Co., Ltd
TEL: 0769-81230179 <https://www.hystypec.com>