

ROHS
Compatible

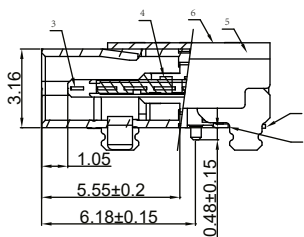

SECTION A-A(剖视图A-A)
SCALE 2:1 (比例 2:1)

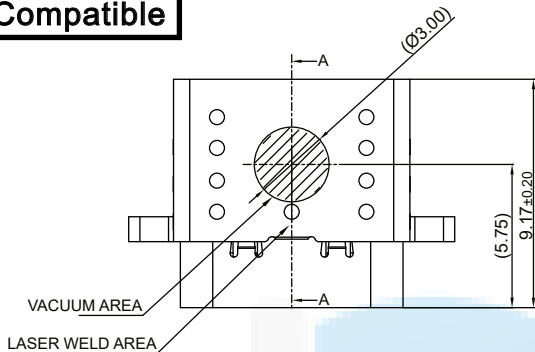
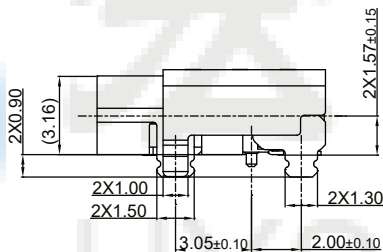
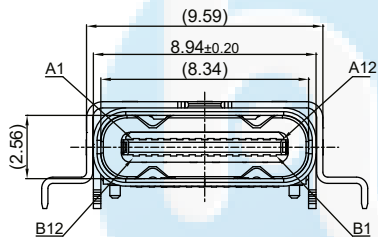

名称 U5 流水号 147- 24P x 0.9J 9.17L
PIN位 N; 母座 J; 脚长 L; 长度

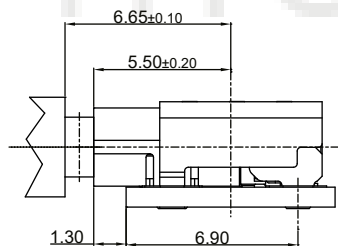
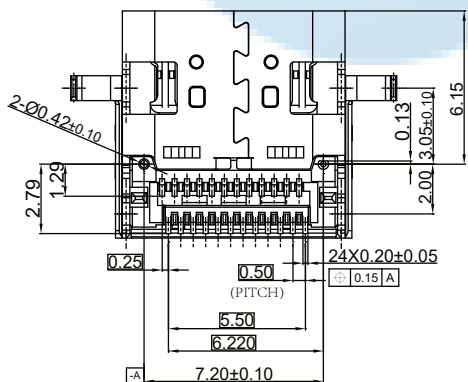
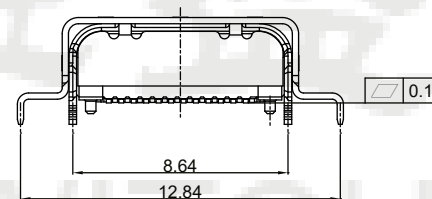

MATED CONDITION(REF.)

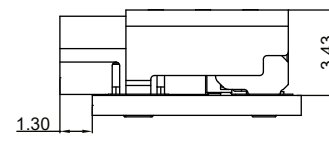

MOUNTING CONDITION(REF.)

H=镀金 1u"
J=镀金 3u"
K=镀金 5u"
M=镀金 15u"
N=镀金 30u"

Pin定义:

A1	A2	A3	A4	A5	A6	A7	A8	A9	A10	A11	A12
GND	TX1+	TX1-	Vbus	CC1	D+	D-	SBU1	Vbus	RX2-	RX2+	GND
GND	RX1+	RX1-	Vbus	SBU2	D-	D+	CC2	Vbus	TX2-	TX2+	GND
B12	B11	B10	B9	B8	B7	B6	B5	B4	B3	B2	B1

DESIGN	Li Jinwei	SCALL	
DRAWING	Wu Qifa	UNIT	mm
CHECK	Zheng Jinxian	SIZE	A4: 210 * 297
APPROVAL	Liu Xiaohong	DATE	2020-06-10

TOLERANCE	
X.X ±0.30	X.°±2°
.XX ±0.20	.X°±1°
.XXX ±0.10	.XX°±0.5°

DRAWG NO.	U5147-24PN0.9J9.17L
TITLE:	24P板上六脚插板双壳 锡脚0.9 9.17L

东莞市宏煜盛实业有限公司
Dongguan hongyusheng Industry Co., Ltd
TEL: 0769-81230179 <https://www.hystypec.com>

ROHS
Compatible

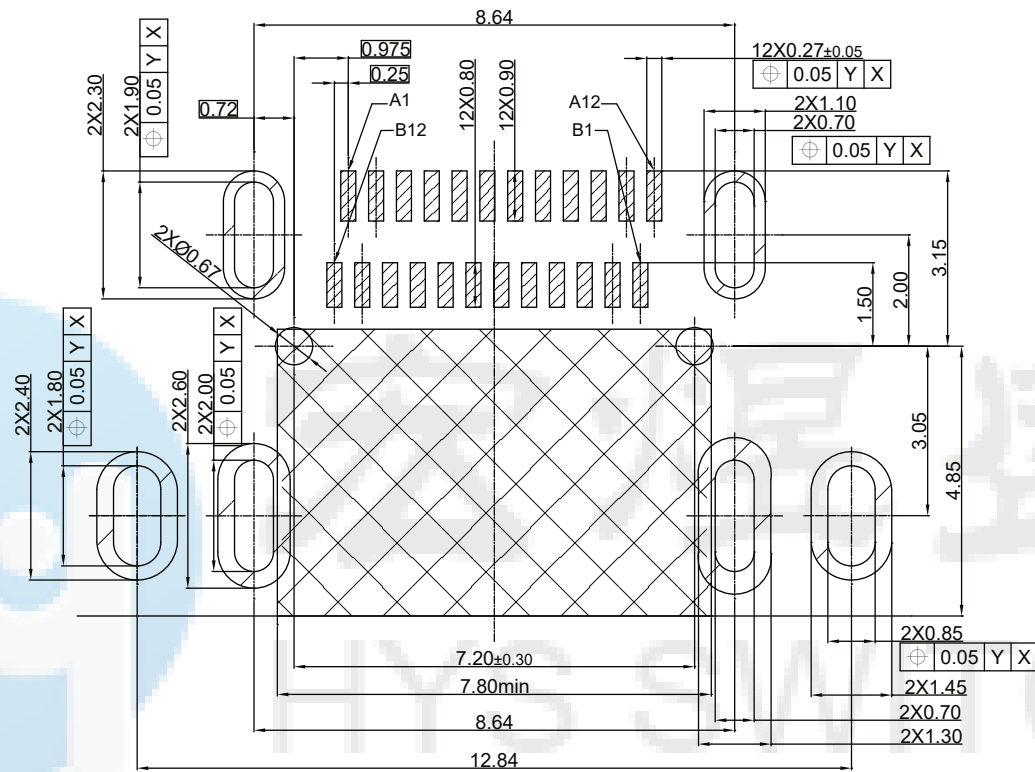

Recommended PCB Layout(Top View)/推荐的PCB布局(前视图)
General Tolerances:±0.05/一般公差:±0.05

6	OUT SHELL	1	SUS304	NICKEL PLATING	0.25mm
5	INT SHELL	1	SUS304	NICKEL PLATING	0.3mm
4	MAIN HOUSING	1	PA9T HF 30%玻纤, UL94 V-0, 黑色	-	COLOR:BLACK
3	MID PLATE	1	SUS301	-	0.15mm
2	BOTTOM TERMINAL	1	C18140	MATING SIDE:SEE PART NO; SOLDER TAIL:GOLD FLASH, 30u" NICKEL OVERALL.	0.12mm
1	TOP TERMINAL	1	C18140		0.12mm
ITEM	DESCRIPTION	Q'TY	MATERIAL	FINISH	REMARK

DESIGN	Li Jinwei	SCALE	
DRAWING	Wu Qifa	UNIT	mm
CHECK	Zheng Jinxian	SIZE	A4: 210 * 297
APPROVAL	Liu Xiaohong	DATE	2020-06-10

TOLERANCE	
X.X ±0.30	X.°±2°
.XX ±0.20	.X°±1°
.XXX ±0.10	.XX°±0.5°

DRAWG NO.	U5147-24PN0.9J9.17L
TITLE:	24P板上六脚插板双壳 锡脚0.9 9.17L

东莞市宏煜盛实业有限公司
 Dongguan hongyusheng Industry Co., Ltd
 TEL: 0769-81230179 <https://www.hystypec.com>

ROHS
Compatible

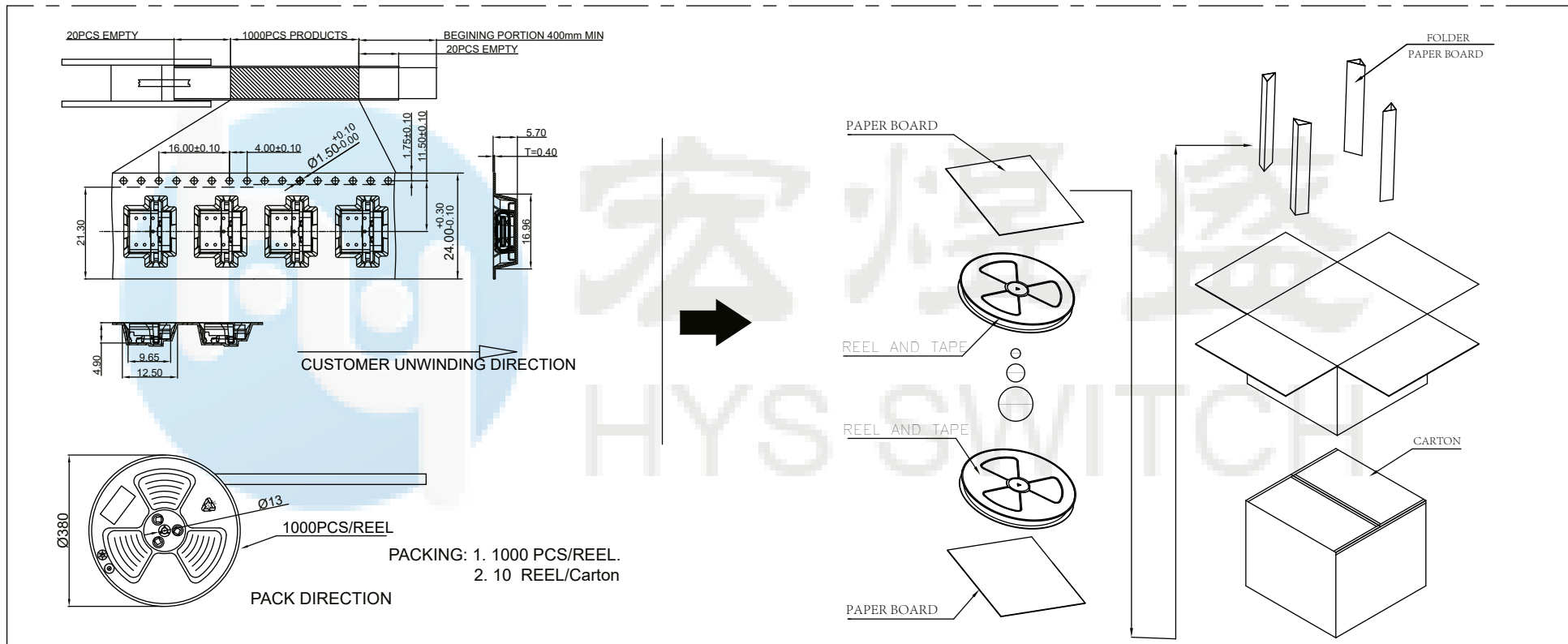

DESIGN	Li Jinwei	SCALE	
DRAWING	Wu Qifa	UNIT	mm
CHECK	Zheng Jinxian	SIZE	A4: 210 * 297
APPROVAL	Liu Xiaohong	DATE	2020-06-10

TOLERANCE	
X.X ±0.30	X.°±2°
.XX ±0.20	.X°±1°
.XXX ±0.10	.XX°±0.5°

DRAWG NO.	U5147-24PN0.9J9.17L
TITLE:	24P板上六脚插板双壳 锡脚0.9 9.17L

东莞市宏煜盛实业有限公司
 Dongguan hongyusheng Industry Co., Ltd
 TEL: 0769-81230179 <https://www.hystypec.com>